



INSTRUCTION MANUAL

MAGNETIC FIELD

STRENGTH METER

MODEL EM-7530

INSTRUCTION MANUAL

THIS INSTRUCTION MANUAL AND ITS ASSOCIATED INFORMATION IS PROPRIETARY. UNAUTHORIZED REPRODUCTION IS FORBIDDEN.

© 1996 ELECTRO-METRICS CORP.

MAGNETIC FIELD

STRENGTH METER

20 Hz - 50 kHz

ELECTRO-METRICS

MODEL EM-7530

SERIAL NO: N/A

ELECTRO-METRICS CORPORATION

231 Enterprise Road, Johnstown, New York 12095
Phone: (518) 762-2600 Fax: (518) 762-2812

EMAIL: info@emihq.com

WEB: <http://www.electro-metrics.com>

MANUAL REV. NO: EM7530-0496

ISSUE DATE: APRIL 01 1996

WARRANTY

This Model EM-7530 Magnetic Field Strength Meter is warranted for a period of 12 months (USA only) from date of shipment against defective materials and workmanship. This warranty is limited to the repair of or replacement of defective parts and is void if unauthorized repair or modification is attempted. Repairs for damage due to misuse or abnormal operating conditions will be performed at the factory and will be billed at our commercial hourly rates. Our estimate will be provided before the work is started.

TABLE OF CONTENTS

SECTION	TITLE	PAGE
I	Introduction and Specifications	S1-1
1.1	Introduction	S1-1
1.2	Receiver Specifications	S1-1
II	Operating Instructions	S2-1
2.1	Operational Precautions	S2-1
2.1.1	Power Source Selector	S2-1
2.1.2	Input Signal Limits	S2-1
2.1.3	Measurement Technique	S2-2
2.1.4	Handling	S2-2
2.2	Power Supply	S2-2
2.2.1	Power Requirements	S2-2
2.2.2	Power Source Selector	S2-3
2.2.3	Fuse Specifications	S2-3
2.2.4	Battery Operation	S2-3
2.2.5	Battery Power Supply	S2-4
2.2.6	Charging The Battery	S2-4
2.2.7	Battery Protection Circuits	S2-5
2.2.7.1	Overcharging	S2-5
2.2.7.2	Excessive Discharge	S2-5
2.2.8	External DC Operation	S2-5
2.3	Operating Procedures	S2-6
2.3.1	Initial Power Up Procedure	S2-6
2.3.2	Sensor Probe Connection	S2-7
2.4	Local Mode Of Operation	S2-7
2.4.1	Sensor Lock Indicator	S2-7
2.4.2	Amplitude Measurement, Front Panel Meter	S2-8
2.4.3	Gain Setting Considerations	S2-8
2.4.4	Amplitude Measurements, Front Panel Analog Output Connector	S2-9
2.4.5	Passband And Notch Filter Functions	S2-10
2.4.6	Frequency Measurement	S2-11
2.5	Remote Operation	S2-11
2.5.1	Equipment Setup	S2-12
2.5.2	Interface Function Codes	S2-12
2.5.3	Bus Address	S2-13
2.5.4	Remote Mode Of Operation	S2-13
2.5.5	Local/Local Lockout Commands	S2-14
2.5.6	Polling	S2-14
2.5.6.1	Serial Poll	S2-14
2.5.6.2	Parallel Poll	S2-14
2.5.7	SRQ (Service Request)	S2-15

TABLE OF CONTENTS

SECTION	TITLE	PAGE
2.5.8	Trigger	S2-15
2.5.9	Device Clear	S2-16
2.5.10	EM-7530 Device Dependent Commands	S2-16
2.5.11	Amplitude Read	S2-17

APPENDICES

APPENDIX	TITLE	PAGE
A	Description Front Panel Controls	A-1
A-1.0	Control Function	A-1
A-2.0	Passband Select Switches	A-1
A-2.1	Lower Limit Passband Select Switch	A-1
A-2.2	Upper Limit Passband Select Switch	A-1
A-3.0	Notch Filter Select Switch	A-1
A-4.0	Passband Indicator Display	A-2
A-5.0	Gain Select Switch	A-2
A-5.1	Gain Select Indicator	A-3
A-6.0	Amplitude Indicator	A-3
A-6.1	Digital Meter	A-3
A-6.2	Analog Meter	A-3
A-7.0	Attenuation Control	A-3
A-8.0	Local Switch	A-3
A-8.1	Remote Indicator	A-4
A-9.0	Sensor Lock Indicator	A-4
A-10.0	Power Switch	A-4
A-11.0	Battery Indicator	A-4
A-11.1	Battery Test Switch	A-5
A-11.2	Charge Indicator	A-5
B	Description Front/Rear Panel Connectors	B-1
B-1.0	Description Front Panel Connectors	B-1
B-1.1	Sensor Connector A1J4	B-1
B-1.2	Calibration Connector A1J5	B-1
B-1.3	Analog Output Connector A1J6	B-1
B-2.0	Rear Panel Connectors	B-1
B-2.1	GPIB Connectors	B-1
B-2.2	AC Power Connector A4J1	B-2

B-2.3	External DC Input Connector A4J2	B-2
C	Function And Description	C-1
C-1.0	Introduction	C-1
C-2.0	Synopsis Of Receiver Operation	C-1
C-3.0	Theory Of Operation	C-2
C-3.1	General	C-2
C-3.2	Variable-Mu Principle	C-2
C-4.0	Circuit Description	C-6
C-4.1	Front Panel PC Board (A1A1)	C-6
C-4.2	RF/Demodulator PC Board (A2A1)	C-7
C-4.3	Output Filter PC Board (A2A2)	C-8
C-4.4	Microprocessor Board (A2A3)	C-9
C-4.5	Power Supply Board (A3)	C-10
C-5.0	Circuit Description: Sensor Probe PC Board	C-11
C-5.1	Sensor Probe PC Board (A6A1)	C-11
D	Applications	D-1
D-1.0	Introduction	D-1
D-2.0	Environmental Measurements	D-1
D-3.0	RFI/EMI Testing	D-1
D-4.0	Shielding Effectiveness Measurements	D-2
D-5.0	Boardband And Narrowband Measurements	D-5
E	Sensor Probe Data	E-1
E-1.0	Introduction	E-1
E-2.0	Magnetic Field Sensor Probes	E-1
E-3.0	E-Field Sensor Probe	E-2

LIST OF TABLES

TABLE	TITLE	PAGE
1.1	EM-7530 Specifications	S1-2
2.1	IEEE STD 488 Interface Function Codes	S2-12
2.2	Status Byte Information	S2-14
2.3	Device Dependent Command Summary	S2-16
C.1	Table Of Equivalent Magnetic Units For $\mu = \mu_0$	C-12

LIST OF ILLUSTRATIONS

FIGURE	TITLE	PAGE
C.1	Characteristics Of Magnetic Materials	C-4
C.2	Ferrite Sensor Rod	C-4
C-3	Block Diagram: Method To Convert Oscillator Frequency Deviation To Useable Readout	C-5
C-4	Block Diagram EM-7530	C-13
D.1	Typical Shielded Enclosure Shielding Effectiveness	D-3
D.2	Laboratory Magnetic Field Environment	D-4
D.3	Magnetic Field Environment Within Enclosure	D-4
D.4	Test Equipment Arrangement	D-5
D.5	Field Measurement Instrumentation Arrangement	D-5

SECTION I EM-7530 INTRODUCTION AND SPECIFICATIONS

1.1 Introduction

The EM-7530 Magnetic Field Strength Meter is a variable- μ magnetometer that performs low-level magnetic fields measurements to MIL-STD-461 and MIL-STD-462 plus other applicable military, government, and industrial (both domestic and international) standards from 20 Hz to 50 kHz.

A built-in microprocessor controls the operation of the unit from information keyed in from the front panel controls. The unit can also be controlled using an external computer via the rear panel IEEE-488 General Purpose Interface Bus Connector.

The EM-7530 uses external sensor probes to detect and measure low-level magnetic fields. The EM-7536 Sensor Probe is supplied with each EM-7530 as a standard accessory. In addition, three optional Sensor Probes are also available--EM-7537, EM-7538, EM-7539.

Liquid Crystal Displays provide accurate readings of signal strength and filter limits. The amplitude measurement is accurate to ± 2 dB.

An internal battery and charger permits field testing at remote locations such as site surveys, field strength measurements near powerlines, and antenna measurements.

1.2 Receiver Specifications

The electrical and general specifications for the EM-7530 Magnetic Field Strength Meter are given in Table 1.1.

**TABLE 1.1
EM-7530 SPECIFICATIONS**

<u>FUNCTION/CHARACTERISTICS</u>	<u>DESCRIPTION/PERFORMANCE</u>
Sensor Probes:	
Standard:	EM-7536: 60-120 dB(pT) Broadband range. (Supplied with each EM-7530).
Optional:	EM-7537: 100-160 dB(pT) Broadband range.
	EM-7538: Uncalibrated, used for pin-pointing localized magnetic sources.
	EM-7539: E-Field Sensor, calibrated, used to measure electric field variations from 20 Hz to 50 kHz.
Front Panel Connectors:	
Sensor:	8-pin Connector-Sensor Probe Input.
Calibration:	BNC, female.
Analog Output:	BNC, female.
Rear Panel Connectors:	
GPIB Interface:	IEEE Std. 488-1978, 24-pin.
External DC Input:	3-pin connector.
Power Requirements:	AC: 105-130 VAC, 50-60 Hz 210-260 VAC, 50-60 Hz
	DC: External DC supply (32 VDC, 800 mA). Internal rechargeable battery pack, operating time approximately six hours.

TABLE 1.1
EM-7530 SPECIFICATIONS

<u>FUNCTION/CHARACTERISTICS</u>	<u>DESCRIPTION/PERFORMANCE</u>
Physical Characteristics:	
Size:	Height: 133 mm (5.25").
	Width: 222 mm (8.75").
	Depth: 368 mm (14.5"). (less handles.)
Weight:	9 kg (20 lbs).

ALL SPECIFICATIONS SUBJECT TO CHANGE WITHOUT NOTICE

**SECTION II
EM-7530
OPERATING INSTRUCTIONS**

CAUTION

READ THIS SECTION BEFORE OPERATING THE EM-7530. IMPROPER OPERATION MAY DAMAGE THE INSTRUMENT.

☞ READ THIS FIRST ☞

2.1 Operational Precautions

2.1.1 Power Source Selector

An AC Power Source Selector is incorporated into the AC Power Input Connector on the rear panel. Check that the selector card displays the correct voltage for the AC power source being used. Operation using a "220" VAC power source with the module set for "110" VAC can cause extensive circuit damage.

2.1.2 Input Signal Level

Do Not Place the Sensor Probe in a DC magnetic field greater than 160 dB(pT) or an AC magnetic field greater than 240 dB(pT) as this will render the Sensor Probe useless.

CAUTION

1. Exposure of the sensor probe to a magnetic field much greater than it is designed to measure will change the permeability characteristic of the ferrite material used within the sensor probe. Any measurements after this occurs will be inaccurate and therefore meaningless.
2. The sensor probe is a sealed non-repairable unit and must be returned to Electro-Metrics for replacement or repair.

2.1.3 Measurement Technique

Do not place the Sensor Probe on or closer than 250 mm (10") from large permeable metallic objects, e.g. cabinets made of cold-rolled steel. This can disturb the bias point of the sensor probe ferrite thus causing inaccurate measurements.

2.1.4 Handling

Do Not drop the sensor probe or subject it to sudden mechanical or thermal shock. The sensor probe ferrite material is very brittle and can be easily cracked or damaged. This will render the sensor probe useless for further measurements.

2.2 Power Supply**2.2.1 Power Requirements**

- a. AC power sources:
 - 1) 105-130 VAC, 50-60 Hz.
 - 2) 210-260 VAC, 50-60 Hz.
- b. **External DC Supply:**
 - 32 VDC, 800 mA.

2.2.2 Power Source Selector

The Power Source Selector is incorporated as part of the power input connector. The number visible in the window indicates the nominal AC power source for which the receiver is set. To change the power source setting:

- a. Remove the power cord from the connector plug.
- b. Slide the clear cover to the left.
- c. Pull the handle marked **FUSE PULL** and remove the fuse.
- d. Push the handle up and gently pull the printed circuit voltage selector card from its slot.
- e. Orient the card so that the desired operating voltage appears on the top-left side.
- f. Firmly push the voltage selector card back into its slot.
- g. Push the **FUSE PULL** handle down and install the correct rating fuse.
- h. Reconnect the AC power cord to the connector.

CAUTION

Verify that the Power Source Selector setting corresponds to the AC power source being used. Operation on "220" VAC with the module set for "110" VAC can cause extensive circuit damage.

2.2.3 Fuse Specifications

The EM-7530 uses the following fuses:

- a. 115 VAC operation: 1.0 AMP 3AG SLO-BLO.
- b. 230 VAC operation: 0.5 AMP 3AG SLO-BLO.

2.2.4 Battery Operation

EM-7530 operation is identical whether using an internal battery or an AC power source except that the battery has a limited or finite time of operation. The approximate state of the battery charge is checked by pressing the Battery Test Switch that converts the analog meter to a battery charge status indicator. For operation using the battery as a sole power source, the meter should read between the two markings of the battery test scale. A reading at or below the lower marking (middle of meter) indicates that the battery requires recharging or replacement.

NOTE: **To obtain the nominal six hours of battery operation, the meter should read at or near the upper scale marking.**

In addition, during periods of extended or heavy usage, it is advisable to check the battery condition periodically.

A fully charged battery will operate the EM-7530 for a nominal six hours. The actual operating time will vary and is dependent on the type of testing the instrument will be performing.

Always charge the battery to full capacity before storing the unit. A fully charged battery can be stored up to three years with no appreciable decrease in battery capacity.

CAUTION

"NEVER" store a lead acid battery in a state of deep discharge.

2.2.5 Battery Power Supply

The battery pack comprises fifteen (15) 5 ampere-hour 2 V lead-acid cells.

The battery can function for a nominal six hours of sustained operation without charging. It will fully recharge after such usage in approximately 16 hours.

2.2.6 Charging The Battery

To charge the battery, connect the EM-7530 to the appropriate AC power source for approximately 16 hours. The charge indicator will be on whenever the receiver is connected to an AC power source. Battery charging is automatically controlled by the instrument and will take place with the Power Switch either ON or OFF, but will take longer with the receiver turned ON.

If the battery pack will not recharge or operate the unit for six hours, it should be replaced. Battery life is a function of many factors in addition to the charge-discharge ratio. To obtain maximum battery life observe the following:

- a.** Operate using an AC power source whenever possible.

- b. Provided the interval between periods of use does not exceed one week, any loss of charge resulting from battery only operation for time (T) can be replenished by recharging with the unit (off) for twice the length of time (2T).

2.2.7 Battery Protection Circuits

2.2.7.1 Overcharging

Overcharging will not occur, since the charger circuit automatically reduces charging current as soon as overcharging reaches a significant level.

2.2.7.2 Excessive Discharge

Excessive discharge will not occur since the flow of battery current to all circuits is automatically interrupted as soon as battery voltage drops to a value indicating negligible remaining capacity.

2.2.8 External DC Operation

Battery operation beyond the six hour limit established by the internal battery pack of the receiver can be accomplished utilizing an external battery setup.

Use the following procedure to set up the EM-7530 for operation from an external battery supply:

- a. Turn OFF the unit and disconnect the internal battery pack plug (P3-A). Transfer the "External DC IN" plug (P3-B) to J3-A and connect the internal battery pack plug (P3-A) to J3-B.
- b. Connect the external battery, minimum voltage level 32 VDC, to the rear panel External DC INPUT Connector (A4J3) using the socket equivalent of the connector (PTO2A-8-3S).

The socket is wired as follows:

- Pin A:** Plus (+) voltage line.
- Pin B:** Minus (-) voltage line.
- Pin C:** No connection

CAUTION

DO NOT GROUND the Battery Terminals or establish a reference ground. The external supply must "FLOAT" with respect to ground.

- c. Turn on the EM-7530. The operation of the receiver should be identical to that with an internal battery or an AC power source.

CAUTION

The EM-7530 "SHOULD NOT" be connected to an AC power source whenever an external DC power source is being used.

2.3 Operating Procedures

- a. **Refer to Appendix-A for a description of the front panel control functions and Appendix-B for a description of the Front and Rear Panel Connectors.**

2.3.1 Initial Power Up Procedure

Before applying power to the EM-7530, check the following:

- a. Power Source Module setting should correspond to the AC power source being used.
- b. **Fuse A4J1-F1** should be correct rating for the AC power source being used.
- c. Connect the power cord between the A4J1 Power Connector and the AC power source.
- d. Turn on the EM-7530 by pushing in the front panel Power Switch. The LCDs should be lighted when the unit is on. Allow a minimum warm-up time of 30 minutes.

NOTE: When operating the unit using the battery pack as the sole power source, the warm-up can be performed using the AC power source to conserve battery power.

2.3.2 Sensor Probe Connection

With the EM-7530 turned-off, connect the Sensor Probe Cable to the front panel Sensor Connector. Connect the Sensor Probe selected to the other end of the Sensor Probe Cable. The unit is now ready for operation.

CAUTION

Always turn the EM-7530 "OFF" before connecting the Sensor probe cable to the front panel sensor connector or the sensor probe to a previously connected sensor probe cable.

2.4 Local Mode Of Operation

In the Local Mode of Operation, the EM-7530 is operated and controlled using the front panel controls of the unit. The information in Sections 2.4.1 thru 2.4.5 will be useful when operating in the Local Mode of Operation.

2.4.1 Sensor Lock Indicator

On the front panel of the EM-7530 is located a Sensor Lock Indicator (LED) that indicates when the internal circuitry and the external probe circuitry are "locked" into the correct operating frequency.

After the selected Sensor Probe is connected to the main unit, turn on the instrument. The "LOCK" light should come on. If the "LOCK" light does not come on, turn off the power switch and repeat the process.

NOTE: Large AC magnetic fields or large permeable metallic objects (e.g. cabinets made of cold-rolled steel) in close proximity to the probe can cause it to lose lock. Lock must be re-established before the sensor can be used for measurement.

Only after a true "LOCK" indication is obtained, can the Sensor Probe be used for making accurate measurements.

2.4.2 Amplitude Measurement, Front Panel Meter

The digital meter of the EM-7530 is used to determine the amplitude (magnetic field strength level) of an input signal. However, since the response time of a digital meter is slow compared to an analog meter, the following procedure is employed:

- a. Using a combination of passband settings and optimum positioning of the Sensor Probe, obtain a maximum indication on the analog meter of the magnetic field strength. To keep the signal within the linear range of the unit, use either the AUTO position or the LOW/HIGH manual positions of the Gain Select Switch.
- b. After the signal is peaked for maximum on the analog meter, read the level indicated by the digital meter.

The **analog meter** is meant for **relative amplitude indication only**.

2.4.3 Gain Setting Considerations

The EM-7530 will linearly measure field strengths within the rated range of the Sensor Probe being used. To ensure accurate amplitude measurements, care should be taken when selecting the gain setting to be used. The EM-7530 has three front panel selectable gain settings: AUTO, LOW, HIGH.

- a. **AUTO:** This setting will automatically select the correct internal gain for optimum amplitude measurement accuracy.
- b. **LOW:** This setting will allow the instrument to measure field strengths to the upper limit of the Sensor Probe being used.
- c. **HIGH:** This setting will allow the instrument to linearly measure field strengths 20 dB or more down from the upper limit of the Sensor Probe being used. Above that point, the measurements may not be accurate.

NOTE: 1) The lower left hand section of the front panel analog meter is marked "INCREASE GAIN". Whenever the analog meter indicator is in this section, the "HIGH" gain setting should be used.

2) If the analog meter indicator is above full scale, the "LOW" gain setting should be used.

3) Using the "AUTO" gain setting will automatically perform Steps 1 and 2 without any interaction required by the operator.

2.4.4 Amplitude Measurement, Front Panel Analog Output Connector

The front panel Analog Output signal can also be utilized for amplitude measurement. An external amplitude measuring instrument, (e.g. tuned narrowband voltmeter such as the Electro-Metrics Model EM-2110) is connected to the Analog Output Connector (A1J6). The following procedure should be used:

- a.** The front panel Attenuation Control must be set to the CAL position (FULL CCW-click stop).
- b.** Connect the EM-2110 or equivalent instrument to the front panel Analog Output Connector (BNC).

NOTE: The external amplitude measuring instrument being used must have an input impedance of 600 ohms or greater.

- c.** Read the indicated voltage level (in dB(μ V)) on the EM-2110 or equivalent instrument.

With the EM-7530 Gain set to LOW and the Attenuator Control set FULL CCW (CAL position, click stop), a 1 V_{rms} \pm 2 dB (120 dB(μ V)) output from the Analog Output Connector is equivalent to the maximum field strength measurement rating of the Sensor Probe being used. For the HIGH gain setting, a 20 dB correction factor is algebraically added to the result.

NOTE: The correction factors for different Sensor Probe levels are automatically added to the front panel digital meter indication.

To convert the Analog Output signal level in dB(μ V) to equivalent magnetic field strength in dB(pT), use the following formula:

$$H = SP_L - (120 - V_M) \text{ dB(pT)}$$

Where:

H = Magnetic Field Strength in dB(pT).

SP_L = Rating Limit of the Sensor Probe being used.

V_M = Measured voltage level in dB(μ V).

Example:

Using the EM-7536 Sensor Probe (standard), measurement range: 60-120 dB(pT) broad-band.

GAIN Setting:LOW
 DIGITAL METER Indication:.....120 dB(pT)
 SENSOR PROBE Rating Limit (SP_L):120 dB(pT)

The Analog Output level V_M should be 120 dB(μ V) \pm 2 dB as measured by the EM-2110.

$$H = 120 - (120 - 120) \text{ dB(pT)}$$

$$H = 120 \text{ dB(pT)}$$

In the HIGH gain setting, subtract 20 dB from the result to obtain the actual magnetic field strength. For the two optional calibrated Sensor Probes, the maximum measurement limits are:

EM-7537: 160 dB(pT)

EM-7539: 160 dB(pT)

2.4.5 Passband And Notch Functions

The EM-7530 uses a series of front panel selectable high pass and low pass filter networks to set a variety of passband ranges. This allows the operator to eliminate frequencies that are not of interest. The Lower and Upper Limit Passband Select Switches are used to select the passband range required.

Example:

Passband range required: 5 kHz to 10 kHz.

Set LOWER LIMIT: 5 kHz.

Set UPPER LIMIT: 10 kHz.

A passband has now been established with a lower 3 dB point of 5 kHz and an upper 3 dB point of 10 kHz. Signals below 5 kHz and above 10 kHz will now be attenuated.

2.4.6 Frequency Measurement

To accurately obtain the frequency of the magnetic field being measured requires the use of an external counter or tunable receiver (e.g. Electro-Metrics Model EM-2110). The device being used must have an input impedance of 600 ohms or greater and is connected to the front panel Analog Output Connector (A1J6).

2.5 Remote Operation

The EM-7530 Magnetic Field Strength Meter is operated remotely using a computer supplying control information through the IEEE Std 488-1978 General Purpose Interface Bus (GPIB).

NOTE: **Computer operation can only be performed with the EM-7530 connected to an AC power source. The GPIB is disabled when the unit is using the internal battery pack as the sole power source.**

The current firmware version level being used by the EM-7530 will be displayed on the front panel Passband Display if the Local pushbutton Switch is pushed when the receiver is in local mode.

Section 2.5.1 provides a typical equipment setup for operation using the GPIB interface.

The commands listed in Section 2.5 are all EM-7530 device dependent commands issued as ASCII commands over the GPIB. EM-7530 Device Dependent Commands are listed in Section 2.5.5. In each case listed, the EM-7530 is a listener as defined in the IEEE Std 488-1978.

Some of the functions controlled through the BUS are:

- | | |
|-------------------------------|----------------------------|
| a. Bus Address | e. Low Pass Filter |
| b. DVM Read | f. High Pass Filter |
| c. Go To Local | g. Notch Filter |
| d. Local Lockout Logic | h. Gain |

2.5.1 Equipment Setup

NOTE: The following setup assumes a test system consisting of an EM-7530 plus computer.

To operate the EM-7530 remotely:

- a. Connect the GPIB Cable (24 pin) to the EM-7530 rear panel IEEE STD 488 Port Connector.
- b. Verify that no other device is assigned the Bus Address for the EM-7530. If assigned to another device, use the procedure in 2.5.3 to select a new bus address for the unit. The new bus address is implemented immediately upon being entered.

NOTE: Always verify that each device on the GPIB network is assigned its own unique bus address before activating the network.

- c. Follow the Initial Power-Up procedure in Section 2.3.1.
- d. Turn on the computer and initiate the software being used.
- e. Connect the selected Sensor Probe to the EM-7530 Sensor Probe Connector. The EM-7530 and associated equipment are now ready for remote operation.

2.5.2 Interface Function Codes

The EM-7530 GPIB operates as both a talker and a listener. The GPIB is compatible with the IEEE STD 488 interface function codes listed in Table 2.1.

TABLE 2.1
IEEE STD 488 INTERFACE FUNCTION CODES

CODE	DESCRIPTION
AH1	Acceptor Handshake Capability
L4	Listener (Basic Listener, Unaddressed to Listen on TAG)
SH1	Source Handshake Capability
CODE	DESCRIPTION
T6	Talker (Basic Talker, Serial Poll, Unaddressed to Talk On LAG)
SR1	Service Request Capability
PP1	Parallel Poll Capability (Remote Configuration)
DC1	Device Clear Capability
DT0	No Device Clear Capability
RL1	Remote/Local Capability
C0	No Controller Capability
E1	Open Collector Bus Drivers
TE0	No Extended Talker Capabilities
LE0	No Extended Listener Capabilities

2.5.3 Bus Address

The current EM-7530 Bus Address will be displayed on the front panel Passband Display if the Local Switch is pushed when the receiver is in local mode.

The bus address can be changed whenever the receiver is in the Local Mode of Operation using the front panel Passband Select Switches as follows:

Upper Limit Switch: Increases the bus address number.
Lower Limit Switch: Decreases the bus address number.

In the Remote Mode of Operation, the bus address can be changed by a command issued by a computer connected to the GPIB Interface Connector on the rear panel. A device dependent command must be issued to the EM-7530 in ASCII in the format shown below.

"ADD:**" Where ** is the number from 0 to 30 of the new desired bus address.

An example is shown below for an HP-9836 Computer.

"OUTPUT 7ZZ; "ADD:**" (Carriage Return/Linefeed)

Where ZZ is the current bus address of the EM-7530 and ** is the new bus address for the EM-7530.

2.5.4 Remote Mode Of Operation

Any of the commands noted in Table 2.3 will automatically switch the EM-7530 to the Remote (computer) Mode of operation from the Local Mode of operation.

The front panel Remote LED is activated whenever the unit is in the remote mode of operation.

2.5.5 Local/Local Lockout Commands

The EM-7530 may be commanded to lockout all the front panel pushbutton switches using a GPIB command. The local lockout command can only be cancelled with a GPIB "Go To Local" command. The format of the ASCII commands are shown below for the HP-9836 Computer.

LOCAL LOCKOUT: **OUTPUT 7ZZ;"LLO"**
LOCAL: **OUTPUT 7ZZ;"GTL"**

Where ZZ is the current bus address of the EM-7530.

If a Local Lockout has not been commanded, the EM-7530 may be brought into the local mode by pushing the front panel Local Switch.

2.5.6 Polling

The computer may periodically check devices on the bus to determine if a particular device needs service, or in response to SRQ to determine which device requested service. Two types of polling may be performed, serial or parallel.

2.5.6.1 Serial Poll

When performing a serial poll, the computer can access each device on the bus individually to read an eight-bit status byte. The computer is then informed of the nature of service required by the polled device. The EM-7530 returns a status byte as shown in Table 2.2.

**TABLE 2.2
STATUS BYTE INFORMATION**

LINES	(8)	(7)	(6)	(5)	(4)	(3)	(2)	(1)
BITS	7	6	5	4	3	2	1	0
VAL- UE	128	64	32	16	8	4	2	1

MEANING: **BIT 0: 1 = hardware error**
BIT 4: 1 = MAV: Message Available
BIT 5: 1 = ESB
BIT 6: 1 = requested service

If the status byte read back is equal to 65, then this indicates that **BIT 6 = 1 (64)** and **BIT 0 = 1 (1)**. In this case, the EM-7530 has requested service for a hardware error.

2.5.6.2 Parallel Poll

Parallel polling provides the computer a quick way to check if any devices require service or to determine which device requested service. The computer can configure the EM-7530 to respond on any one of eight data lines with up to two devices per data line. When performing a parallel poll the device needing service will assert the particular line assigned to it. This allows the computer to see all devices on the bus at once and attend to only those requiring service. When two devices are assigned to one line, a serial poll of each device will be necessary to determine which of the two require service.

Please refer to your computer software manual for complete details of parallel poll configure and parallel poll unconfigure.

2.5.7 SRQ (Service Request)

The service request is a signal that the EM-7530 can send to the controller to let it know that the unit requires some kind of attention. When the SRQ is enabled, using the Service Request Enable Register (*SRE) common command, the unit will assert the SRQ line of the GPIB. This can occur whenever a hardware error has occurred in the unit dependent upon the SRQ Mask settings.

The unit will assert SRQ until the computer performs a serial poll, or the fault condition is corrected.

To enable the EM-7530 to SRQ the computer, the *SRE function must be used in the following form:

*SRExxx where xxx is equal to the value of the bits corresponding to the condition which will SRQ the computer.

If an SRQ is desired for a hardware error condition then the value of xxx will be 1 (**BIT 0 = 1**).

An example is shown below for an HP-9836 Computer:

Type: OUTPUT 701;"*SRE1" (hit Execute)

With **xxx = 0**, the EM-7530 will never request service (default condition).

Please refer to previous section on Serial Poll for bit assignments.

NOTE: **The SRE function will not put the EM-7530 into the remote mode. Only numeric values in the range of 0 to 255 should be used with the *SRE function, otherwise unexpected results may occur.**

2.5.8 Trigger

The GET command can be used to take a reading with the EM-7530 at the instant the command is asserted. The reading is stored in a buffer for retrieval on the next readback from the EM-7530.

The GET command will not put the EM-7530 into remote mode.

An example is shown below for an HP-9836 Computer:

Type: TRIGGER 701 (hit Execute)

This will force the reading for the unit at bus address 1.

2.5.9 Device Clear

The DCL command may be used to clear the output/input buffers, event status register, and reset the command parser of the unit.

An example is shown below for an HP-9836 Computer:

Type: CLEAR 7 (hit Execute)

The SDC command performs the same function as DCL except that only the addressed device responds.

An example is shown below for an HP-9836 Computer:

Type: CLEAR 701 (hit Execute)

2.5.10 EM-7530 Device Dependent Commands

EM-7530 Device Dependent Commands are listed in Table 2.1.

This device follows the ANSI/IEEE Std 488-1978 standard for codes, formats, protocols, and common commands.

Input and output buffer lengths are 80 characters long. The parser strips commands from the input buffer and implements them in sequential fashion. There is no capability for overlapped commands. Because of this, the effect of certain mandatory common commands may be trivial.

**TABLE 2.3
DEVICE DEPENDENT COMMAND SUMMARY**

FUNCTION	COMMAND	DESCRIPTION
LOWER LIMIT (HIGH PASS FILTER 3 dB)	"HPF:P02" "HPF:P10" "HPF:P20" "HPF:P50" "HPF:1P0" "HPF:2P0" "HPF:5P0" "HPF:10P" "HPF:20P"	Selects 20 Hz High Pass. Selects 100 Hz High Pass. Selects 200 Hz High Pass. Selects 500 Hz High Pass. Selects 1 kHz High Pass. Selects 2 kHz High Pass. Selects 5 kHz High Pass. Selects 10 kHz High Pass. Selects 20 kHz High Pass.
LOWER LIMIT (LOW PASS FILTER 3 dB)	"LPF:P10" "LPF:P20" "LPF:P50" "LPF:1P0" "LPF:2P0" "LPF:5P0" "LPF:10P" "LPF:20P" "LPF:50P"	Selects 100 Hz Low Pass. Selects 200 Hz Low Pass. Selects 500 Hz Low Pass. Selects 1 kHz Low Pass. Selects 2 kHz Low Pass. Selects 5 kHz Low Pass. Selects 10 kHz Low Pass. Selects 20 kHz Low Pass. Selects 50 kHz Low Pass.
GAIN	"GAIN:LOW" "GAIN:HIGH" "GAIN:AUTO"	Selects Low Gain. Selects High Gain. Selects Auto Gain.
NOTCH FILTER	"FLTR:OUT" "FLTR:IN"	Turns OFF Notch Filter. Turns ON Notch Filter.
GPIB ADDRESS	"ADD:**"	Sets GPIB Address of EM-7530. ** is address from 0 to 30.
LOCAL LOCKOUT	"LLO"	Locks out front panel LOCAL pushbutton switch.
LOCAL SELECT	"GTL"	Release local lockout and returns EM-7530 to LO- CAL.

2.5.11 Amplitude Read

The front panel AMPLITUDE DVM of the EM-7530 is derived from an A/D converter that is controlled by the microprocessor in the EM-7530.

Each time the EM-7530 is set as a talker, the microprocessor outputs the DVM reading that was sampled. In all cases, the EM-7530 will output three digits. The numbers may range from 40 to 199.

APPENDIX A
EM-7530
DESCRIPTION FRONT PANEL CONTROLS

A-1.0 Control Functions

All controls for operation of the EM-7530 Magnetic Field Strength Meter are located on the front panel.

A-2.0 Passband Select Switches

A-2.1 "Lower Limit" Passband Select Switch (High Pass Filter Select)

Type: Momentary pushbutton switch.

Quantity: 1.

Function: To select one of nine (9) high pass filter networks with 3 dB cutoff frequencies of:

20 Hz, 100 Hz, 200 Hz, 500 Hz, 1 kHz, 2 kHz, 5 kHz, 10 kHz, 20 kHz.

The high pass filter selected is indicated on the left-hand side of the Passband Indicator Display.

A-2.2 "Upper Limit" Passband Select Switch (Low Pass Filter Select)

Type: Momentary pushbutton switch.

Quantity: 1.

Function: To select one of nine (9) low pass filter networks with 3 dB cutoff frequencies of:

100 Hz, 200 Hz, 500 Hz, 1 kHz, 2 kHz, 5 kHz, 10 kHz, 20 kHz, 50 kHz.

The low pass filter selected is indicated on the right-hand side of the Passband Indicator Display.

A-3.0 Notch Filter Select Switch

Type: Momentary pushbutton switch.

Quantity: 1.

Indicator: LED, integrated into switch.

Function: Turns on the Notch Rejection Filter circuitry with fixed notch frequencies of 60 Hz and 180 Hz. In addition, optional notch frequencies of 50 Hz and 150 Hz are available on request.

An integral LED indicator indicates when the Notch Filter circuitry is turned ON.

A-4.0 Passband Indicator Display

Type: Liquid Crystal Display, four digit--backlighted.

Function: Indicates the passband measurement range of the unit in kHz. The left-hand side of the display indicates the lower limit of the passband (high-pass filter) selected and the right-hand side of the display indicates the upper limit of the passband (low-pass filter) selected.

A-5.0 Gain Select Switch

Type: Momentary pushbutton switch.

Quantity: 1.

Function: To select one of three gain settings: LOW, HIGH, AUTO.

NOTE: **The terms Low and High gain refer to relative indications of the overall sensitivity of the EM-7530.**

a. LOW

Adjusts the internal gain of the EM-7530 to a specified low setting.

b. HIGH:

Adjusts the internal gain of the EM-7530 to a specified high setting.

c. AUTO:

Automatically adjusts the internal gain of the EM-7530 between the Low and High gain settings to produce an accurate output versus field strength inputs from 20 Hz to 50 kHz.

A-5.1 Gain Select Indicator

Type: LED.

Color: Red.

Quantity: 3.

Function: To indicate which gain setting (LOW, HIGH, AUTO) is selected.

A-6.0 Amplitude Indication

The EM-7530 utilizes a dual metering system, with digital and analog meters, to indicate the field strength (amplitude) level of a detected magnetic field.

A-6.1 Digital Meter

Type: Liquid Crystal Display, three digit--backlighted.

Function: Indicates the magnetic field level in dB(pT).

A-6.2 Analog Meter

Type: 1-inch analog meter.

Function: For ease in tuning.

UNCALIBRATED, RELATIVE INDICATION ONLY.

A-7.0 Attenuation Control

Type: Cermet single turn, 280° rotation, 10 kΩ.

Function: Varies the amplitude output level of the signal present at the front panel Analog Output Connector.

When the control is FULL CCW (CAL position, click stop), the rms voltage from the Analog Output Connector will be scaled to the magnetic field strength.

A-8.0 Local Switch

Type: Momentary pushbutton switch.

Quantity: 1.

Function: To select the Local mode of unit operation. A separate Remote indicator (LED) is activated when the Remote mode of operation is selected. The Remote Mode can only be selected thru a GPIB BUS Command.

NOTE: **The receiver can be locked into the Remote mode when the computer issues a Local Lockout command through the GPIB Interface Bus. Under these conditions, pushing the Local Switch will have no effect. The computer must issue a command to return the receiver to the Local mode of operation.**

A-8.1 Remote Indicators

Type: LED.

Color: Red.

Function: To indicate when the Remote mode of operation is selected.

A-9.0 Sensor Lock Indicator

Type: LED.

Color: Red.

Function: To indicate when the internal circuitry and the external probe circuitry are "locked" into the correct feedback and operating frequency.

A-10.0 Power Switch

Type: Two cycle pushbutton switch

Function: Self-explanatory.

A-11.0 Battery Indicator

The lower right hand section of the front panel Analog Meter indicates the approximate condition of the internal battery pack whenever the Battery Test Switch is pressed.

A-11.1 Battery Test Switch

Type: Momentary pushbutton switch.

Function: Disconnects the front panel Analog Meter from the internal meter circuitry and places the battery, through a meter protection circuit, across the meter.

A-11.2 Charge Indicator

Type: LED.

Color: Red.

Function: To indicate when an AC power source is connected to the unit.

APPENDIX B
EM-7530
DESCRIPTION FRONT/REAR PANEL CONNECTORS

B-1.0 Front Panel Connectors

The following is a description of the front panel connectors for the EM-7530

B-1.1 Sensor Connector A1J4

Type: 8-pin connector.

Function: Connects the Sensor Probe selected (EM-7536, EM-7537, EM-7538, or EM-7539) to the EM-7530. Supplies power, calibration, and logic signals to and receives input signals from the sensor connected.

B-1.2 Calibration Connector A1J5

Type: BNC, receptacle.

Function: To apply an external signal to the selected Sensor Probe to simulate a known magnetic field strength level for checking the measurement accuracy of the selected probe.

B-1.3 Analog Output Connector A1J6

Type: BNC, receptacle.

Function: Provides an output whose frequency is that of the magnetic field being measured. The rms voltage is scaled to the magnetic field strength when the Attenuation Control is FULL CCW (CAL position, click stop).

B-2.0 Rear Panel Connectors

The following is a description of the rear panel connectors for the EM-7530.

B- 2.1 GPIB Connector (A3J1)

Type: IEEE Std 488.2-1978 General Purpose Interface Bus Connector (24-pin).

Function: Interfacing a computer with the EM-7530.

B-2.2 AC Power Connector (A4J1)

Type: Combined voltage selecting and fuse holder.

Function: Self explanatory.

B-2.3 External DC Input Connector A4J2

Type: 3-pin connector (PTO2A-8-3P)

Function: To connect an external 40 VDC supply to the EM-7530.

APPENDIX C EM-7530 FUNCTION AND DESCRIPTION

C-1.0 Introduction

This section contains a brief description of unit and circuitry function for the EM-7530 Magnetic Field Strength Meter.

C-2.0 Synopsis Of Unit Operation

(Refer to Figure C.4)

The EM-7530 Magnetic Field Strength Meter is a variable-mu magnetometer that performs low-level magnetic fields measurements to MIL-STD-461 and MIL-STD-462 plus other applicable military, government, and industrial (both domestic and international) standards from from 20 Hz to 50 kHz.

A built-in microprocessor controls the operation of the unit from information keyed in from the front panel controls. The unit can also be controlled using an external computer via the rear panel IEEE-488 General Purpose Interface Bus Connector.

The EM-7530 MFS Meter is divided into four major sections:

- External Sensor Probe,
- RF Demodulator circuitry,
- Output Filter circuitry,
- RMS-DC Converter circuitry.

The external Sensor Probe detects and measures low-level magnetic fields. Each Probe consists of a ferrite sensor and sensor oscillator circuit that supplies a 3 MHz (approx.) frequency modulated (FM) signal to the main unit.

The RF Demodulator circuitry demodulates the FM signal to produce a low frequency demodulated signal. The circuitry also includes a feedback circuit that controls the center frequency of the Sensor Probe oscillator. This compensates for shifts in the magnetic field of the earth or for sub-audio frequency magnetic fields.

The Output Filter circuitry processes the low frequency demodulated signal using selectable notch plus low and high pass filter circuitry. The notch filters suppress the power line

fundamental and 3rd harmonic frequencies. The low and high pass filters set the passband for the unit.

The RMS-DC Converter circuitry converts the processed rms signal to a DC voltage scaled to the input signal amplitude. This is then sent, after processing by the Microprocessor circuitry, to the front panel amplitude display.

Liquid Crystal Displays provide accurate readings of signal strength and filter limits. The amplitude measurement is accurate to ± 2 dB.

An internal battery and charger permits field testing at remote locations such as site surveys, field strength measurements near powerlines, and antenna measurements.

C-3.0 Theory Of Operation

C-3.1 General

The EM-7530 Magnetic Field Strength Meter is based on the patented Variable-Mu Principle. The EM-7530 provides combinations of bandwidth and sensitivity that make it a unique instrument for magnetic field measurements in the VLF (Very Low Frequency), ELF (Extremely Low Frequency), and audio frequency ranges.

C-3.2 Variable-Mu Principle

The Variable-Mu Principle utilizes the properties of ferrite materials for measuring magnetic field strengths. Figure C.1a is representative of the B and H characteristics of typical ferrite materials, where B is the induced flux density and H is the magnetic field strength.

The incremental permeability, $\mu\Delta$, shown in Figure C.1b, is derived by calculating $\Delta B/\Delta H$ for small changes in H. If the quiescent point is fixed at H_0 , indicated in both figures, a small change in H will cause a small change in $\mu\Delta$.

If the ferrite material is in the form of a rod with an aperture ground through it (Fig. C.2), then the ferrite around the aperture forms a toroidal-like core. If wire is wound through the core forming an inductor, then variations in H will produce changes in the inductance (L) since it is directly proportional to $\mu\Delta$.

If the inductor is used in the frequency determining circuit of an oscillator, variations in the impinging H-Field will result in corresponding changes in the oscillator frequency. The frequency variation is derived as follows:

$$f = \frac{1}{2\pi\sqrt{LC}}$$

Where:

f = frequency (Hz),

L = inductance (Henrys),

C = capacitance (Farads).

Differentiating with respect to the magnetic field strength, H:

$$\frac{df}{dH} = \frac{f}{2} \frac{dL}{L} \frac{1}{dH}$$

But: $L = k\mu\Delta$

and $dL = kd\mu\Delta$

where $k = \alpha$ constant.

Therefore:

$$\frac{1}{f} \frac{df}{dH} = \frac{1}{2\mu\Delta} \frac{d\mu\Delta}{dH}$$

The percentage change in frequency for a given change in H is thus directly proportional to the change in $\mu\Delta$ and inversely proportional to the magnitude $\mu\Delta$. With this information, the point on the $\mu\Delta$ vs H curve that gives maximum deviation can be selected. This will also be the point of maximum sensitivity since the amplitude of the change in the magnetic field strength is measured by detecting the frequency deviation of an oscillator. The ferrite material is biased at the point of maximum sensitivity by fixing small permanent magnets to the ends of the ferrite rods. The residual induction of the magnets is varied to obtain the proper magnetic bias.

Block diagram, Figure C.3, illustrates the method used to convert the oscillator frequency deviation to a useable readout.

If a time varying H-Field (ΔH) is applied, a frequency shift (Δf) in the sensor oscillator is produced at the same rate of change as the applied field. The magnitude of the frequency shift is linearly proportional to the peak amplitude of ΔH . The sensor oscillator frequency ($f_s + \Delta f$) is then mixed with a constant frequency (f_{LO}) from the local oscillator. The difference frequency ($f_{LO} - (f_s + \Delta f)$) is demodulated to produce an analog voltage (V) which is proportional to the magnitude of ΔH and varies at the same time rate. A steady magnetic field (H) applied to the sensor does not produce a frequency shift in the sensor because of the servo control-type circuitry.

Figure C.1
Characteristics Of Magnetic Materials

Figure C.2
Ferrite Sensor Rod

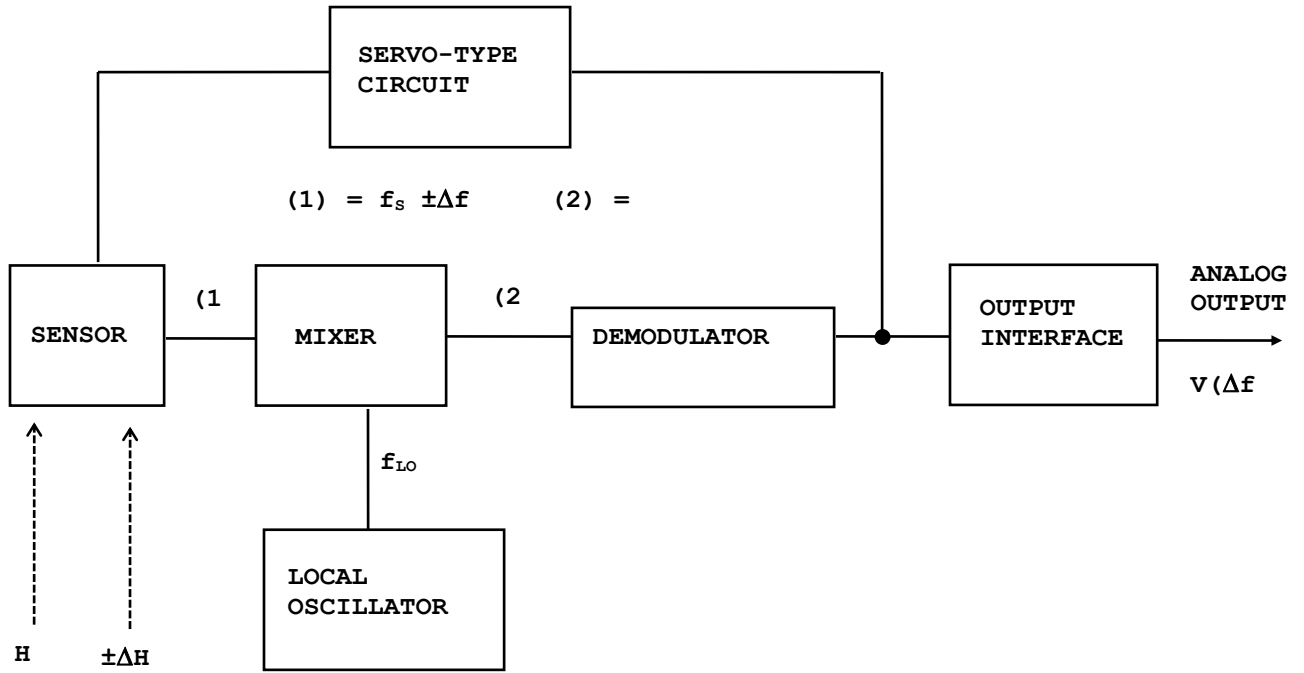

Figure C.3
Block Diagram:
Method To Convert Oscillator
Frequency Deviation To Useable Readout

The low frequency response of a variable-mu magnetometer is thus controlled by the upper frequency response of the servo-type circuitry. The use of the servo technique allows operation of the instrument without concern as to the sensor orientation in the magnetic field of the earth.

The upper frequency response of the variable-mu magnetometer is limited, operationally, by the allowable bandwidth of the mixer circuitry. Mixer circuitry of the configuration used in the variable-mu magnetometer is limited by the minimum allowable difference in the carrier and local oscillator frequencies such that unwanted mixer products do not occur.

A more practical limitation of the upper frequency response is the maximum allowable bandwidth that can be used in a typical environment and still maintain a usable sensitivity. The total broadband response of the instrument to a constant energy spectrum is approximately proportional to the square root of the bandwidth; thus, a typical environmental level might generate a response great enough that even with narrowband monitoring techniques the sensitivity level inherent in the instrument could not be achieved. The upper frequency response of an instrument should be set such that only the bandwidth required to obtain the truly significant information is used. Using a bandwidth that is too wide will result in reduced usable sensitivity for a given environment.

C-4.0 Circuit Description: Main Unit

C-4.1 Front Panel PC Board (A1A1)

The Front Panel Board is the interface between the front panel displays-switches-indicator lights and the Microprocessor Board A2A3.

The LCD displays for indicating Amplitude and Passband are driven by decoders-drivers that receive their input data from the Microprocessor Board. The analog meter receives its input from the Output Filter Board and is for relative indication only. It is normally used for "peaking-in" signals, using the Passband Select Switches and Notch Filters (if required), with the actual amplitude reading being obtained from the LCD display.

The majority of front panel pushbutton switches are part of a keyboard encoder circuit that provides the logic data keyed in by the switches to the Microprocessor Board. In addition, the data is supplied to a series of latching circuits that in turn activate LED indicators. The indicators provide a visual indication of the switch functions activated.

The supply voltages and sensor probe logic to, plus the modulated RF signal from the selected sensor probe are routed through the Front Panel Board from the front panel Sensor Connector. The sensor probe logic is obtained from the Sensor Probe and applied to the Microprocessor Board (A2A3) through the Output Filter Board (A2A2).

Relay K0 controls the output to the analog meter. When K0 is de-energized, the analog meter is indicating the relative amplitude of the detected magnetic field. When K0 is energized, the analog meter indicates the approximate state of the battery charge.

C-4.2 RF/Demodulator PC Board (A2A1)

The RF/Demodulator Board converts the frequency modulated RF signal from the Sensor Probe to a low frequency analog signal. The amplitude of the output signal corresponds to magnetic field strength and its frequency corresponds to the frequency of the magnetic field. The RF/Demodulator also contains a feedback loop that stabilizes the nominal frequency of the sensor probe oscillator.

The sensor probe supplies a 3 MHz (nominal) frequency modulated signal that is modulated by the time-varying amplitude of an AC magnetic field. The frequency modulated signal is processed through four tuned circuit amplifiers (Q0-Q3) and three X2 multipliers (CR0-CR2) stages to produce a frequency modulated 24 MHz (nominal) RF signal. The FM signal is applied to a mixer (IC0) with an LO frequency of 24.2 MHz. The output of mixer IC0 is applied to a 300 kHz lowpass filter (L0, L1, C13, C22, C23, C30-C32) that removes the harmonics of the two mixed frequencies.

The 200 kHz frequency modulated sinewave is next applied to a comparator (IC1), that transforms the sinewave to a squarewave. The frequency modulated 200 kHz squarewave is supplied to a one-shot multivibrator (IC2). The multivibrator output (IC2-6) is set for a positive pulsewidth of 2.5 μ s. This pulse is inverted by Q5 and goes to a current amplifier (IC3) whose output (IC3-4) is applied to a 50 kHz lowpass filter.

The lowpass filter transforms the 200 kHz frequency modulated squarewave into a sinewave. The amplitude of the sinewave corresponds to the peak frequency deviation of the squarewave and its frequency corresponds to the rate of deviation of the squarewave (in the 20 - 50 kHz range). The LO filter output goes to a unity gain buffer (IC4-5) that supplies the signal to the Output Filter Board (A2A2) and to the sensor oscillator feedback circuitry.

The feedback circuitry (IC4) controls the center frequency of the oscillator in the sensor probe. It compensates for shifts in the magnetic field of the earth or sub-audio frequency magnetic fields. As previously mentioned, the output (IC4-7) is a sinewave if an AC magnetic field is being measured. The average voltage of this sinewave will be equal to a reference voltage at IC4-3 if the center frequency of the sensor oscillator is 3 MHz.

The feedback circuit output (IC4-1) is applied to the Sensor Probe PC Board as the tuning voltage for a varactor in the oscillator circuit. Thus the voltage at IC4-1 will vary to keep the center frequency of the probe oscillator locked at 3 MHz. This voltage also goes to IC5-2 and 5. Providing that the voltage at IC4-1 is between approximately +9 V and -9 V (indicative of the probe oscillator being locked at 3 MHz) the voltage at IC5-1 or IC5-7 will turn on transistor Q6, which pulls the voltage at J1-4 to a logic low level. The Microprocessor Board (A2A3) monitors this point and turns on the front panel "LOCK" LED when this output is low.

C-4.3 Output Filter PC Board (A2A2)

The Output Filter Board converts the demodulated low frequency signal from the RF/Demodulator Board (A2A1) (using the selectable notch/passband filter circuitry) to a DC voltage level scaled to the input signal amplitude. The DC voltage is then sent to the Microprocessor Board (A2A3) for use by the Amplitude Display circuitry that drives the front panel amplitude meter display circuitry.

The scaled DC signal is also sent to the front panel Analog Output connector where it can be monitored by an external frequency counter or tunable instrument (e.g. Electro-Metrics Model EM-2110).

The demodulated signal from the RF/Demodulator Board (A2A1) is applied (J1-5 FM VIDEO) to the Output Filter Board. The signal path within the board is dependent on the Low Pass/High Pass Filter logic (J3-2-4, 6-8) and Notch Filter logic (J2-3). If the Notch Filter logic is high, the signal goes directly to the 60/180 Hz notch filters (50/150 Hz optional) that consists of IC0 and IC1 (60 Hz) and IC2 and IC3 (180 Hz) plus respective filtering components. The notch filters provide better than 40 dB suppression of the power line fundamental and its 3rd harmonic frequency. Whenever the unit is turned-on, the notch filters are automatically enabled.

From either IC3-14 (notch filter selected) or IC15-12 (notch filter not selected), the signal can follow one of two paths. If a High-Pass Filter (other than 20 Hz) is selected, the signal is routed to IC4, IC7, IC8, IC9, IC10, plus related components. The configuration of input capacitors (C9-C12) and resistors selected by switching IC7-IC10 form a High-Pass Filter. The four stages of IC4 are unity gain buffers. From IC4-14 or IC15-1 (if the 20 Hz High-Pass Filter is selected), the signal proceeds on.

If a LP filter, (other than 50 kHz) is selected, the signal is routed to IC5, IC11-14, plus related components. The configuration of capacitors (C13-C20) and resistors selected by switching IC11-IC14 (controlled by logic from Microprocessor Board) form a Low Pass Filter. The four stages of IC5 are unity gain buffers.

From IC5-14 or IC15-3 (50 kHz Low Pass Filter is selected), the signal is applied to the RMS-to-DC converter circuit. IC6(1-3) plus R116, R117, R46, R47, and C21 comprise a variable gain stage. If the gain logic (J2-2) is low, then the gain of IC6 is determined by the ratio of R117 and R47 to R116. If the gain logic is high, R46 is placed in parallel with R116 (switched in by IC17) increasing the resistor ratio and the gain of IC6 by 20 dB. This feature is useful in amplifying low-level signals. The signal is then applied to another stage of IC6(5-7), where further amplification takes places. The signal is next applied to IC18, whose output is a DC voltage that is scaled according to the rms amplitude of the input signal. The DC voltage is applied to another stage of IC6(8-10), where it is rescaled and applied to the Microprocessor Board for digital amplitude display (J2-4) and to the front panel analog meter (J4-1).

The signal output from IC6-1 is also applied through the front panel Attenuator Control (A1A1R8) to another stage of IC6 (12-14) that functions as a unity gain buffer. It is next applied to IC20, a current amplifier, whose output is applied to the front panel Analog Output (A1J6).

The Analog Output provides an rms voltage whose frequency is that of the magnetic field being measured. When the front panel Attenuator Control is FULL CCW (CAL position, click stop), the rms voltage from the Analog Output Connector will be scaled to the magnetic field strength. The level of the rms voltage can be measured using an external rms voltmeter or equivalent. The frequency of the rms voltage can be measured using an external counter or equivalent.

C-4.4 Microprocessor Board (A2A3)

The internal Microprocessor Assembly contains the control circuitry for the EM7530. Information is received from the front panel switches-controls or via the rear panel GPIB Connector, then processed. The resultant logic commands are sent to the appropriate internal circuits which then respond in accordance with the commands received.

The microprocessor chip (IC7) is the key element of the control system. It receives, processes, and outputs information to the circuitry within the unit. Associated with the microprocessor chip are the EPROM (Erasable Programmable Read Only Memory) chip (IC11), RAM (Random Access Memory-read/write memory) (IC12), and clock circuit.

The EPROMs are programmed with the permanent information and data required to operate the unit within the specification limits.

The RAM chips are updated during the operation of the unit with information from the front panel switches-controls, data from logic outputs initiated within the circuitry of the unit, or via the rear panel GPIB Connector.

The clock circuit, comprising Crystal Y0 and two capacitors to ground, supplies the 4.0 MHz clock required to drive the microprocessor chip.

Interfacing the microprocessor circuit with the functions to be controlled within the unit is performed by the PIA (Peripheral Interface Adapter) chips (IC13, IC14). An A to D converter circuit (IC15) is used to convert analog signals (amplitude reading, etc) to digital signals which can be then "read" by the microprocessor.

The GPIB data from the rear panel GPIB Connector is applied through IC9, and IC10 which function as bus transceivers.

The data outputs from the bus transceivers are applied to IC8, a GPIA (General Purpose Interface Adapter) which interfaces the GPIB data with the microprocessor chip (IC7). The data outputs from U3 are applied through buffers (IC4-IC6) to the microprocessor.

IC8, IC9, and IC10 are operational only when the unit is connected to an AC power source. The +5 VDC supply for the ICs' is controlled by relay K0 that is energized when a bus transceiver enable voltage is received from the Power Supply (A3).

C-4.5 Power Supply Board (A3)

The Power Supply Board supplies the regulated voltages used by the unit and is located at the rear of the unit. The circuitry on the board can be divided into four subcircuits:

- Rectifier circuit,
- Charge circuit,
- Low voltage cutoff circuit,
- Regulator circuit.

The unit can operate from either an external AC voltage source, internal battery pack, or an external DC input.

The rectifier circuitry provides the "raw" DC voltages for the charge and regulator circuits. The circuit consists of a power select module, power transformer (XF0), rectifier diode pack (D2), and filter capacitor (C9). The power select module combines the power connector, fuse holder, and AC voltage selector into one unit.

When the power switch is depressed, the rectified "raw" DC voltage (or battery voltage) is applied to two capacitors (C0, C1). These capacitors charge and provide a brief positive potential to the base of Q1, which saturates and energizes relay K1. The DC voltage is then applied to IC2-3, which keeps Q2 saturated and K1 energized. The DC voltage is next applied to IC1 (+12 VDC regulator). The output, IC1-3, is next applied to IC2-2. If the unit is operating from the battery pack and the battery voltage falls below a certain point (indicating a need for recharging) IC2 senses the minimum level and shuts off Q1. This de-energizes K1, preventing further current drain. The circuit will remain off even if the battery voltage climbs back above the minimum level since the sensing circuit is on the applied power side of the cutoff circuit. The front panel power switch must be cycled to turn on the unit again.

The charge circuit provides the charging current required to maintain the internal battery pack of the unit at a nominal operating voltage level of 2 volt per cell. A rectified DC voltage is supplied to Q0, which along with R0 and DZ0 comprise a current limiting circuit. The voltage is applied to a constant voltage source (IC0), whose output (IC0-2) is applied to the battery. This results in a self-limiting charge system in which overcharging will not occur if the circuit is functioning correctly.

The regulator circuit provides the +12 VDC, +5 VDC, +5 VDC Filtered, -12 VDC, -12 VDC filtered, and -5 VDC regulated voltages for the instrument. The +12 VDC supply voltage from IC1-3 is the input voltage for the +5 VDC regulator (IC4). IC4 plus associated components produces the +5 VDC and filtered +5 VDC for the unit. The series regulator IC2 operates at 24 volts and supplies Q2 (-12 VDC shunt regulator). Q2 equalizes the current drain between the +12 VDC and -12 VDC supplies. The -12 VDC is provided to the unit as -12 VDC and -12 VDC filtered and is the input voltage for the -5 VDC regulator that provides the -5 VDC to the unit.

C-5.0 Circuit Description: Sensor Probe

C-5.1 Sensor Probe Pc Board (A6A1)

The external Sensor Probes are hand-held devices performing the function of detecting and measuring the low-level magnetic fields. Three probes are currently available for use with the EM-7530:

EM-7536, EM-7537, EM-7538.

The EM-7536 is standard with each unit, while the other two are optional accessories. The basic design is identical for all three probes, the only difference is the ferrite material used for the sensor. The following description is therefore applicable to all four probes.

The Sensor Probe sends to the main unit a 3 MHz (nominal) frequency modulated signal in which the peak deviation is proportional to magnetic field strength while the rate of deviation corresponds to the frequency of the AC magnetic field. A feedback voltage from the main unit stabilizes the center frequency of the oscillator.

The oscillator circuit is comprised of L1, L2, C2, CR2, and Q2. L1 and L2 are coils that are wrapped around the ferrite sensor. A time varying magnetic field introduces changes in the permeability (μ_o) of the ferrite. This changing μ_o causes a change in the inductance of coils L1 and L2. L2, C2, and CR2 (whose capacitance is controlled by a feedback voltage) have a resonant frequency of 3 MHz in static conditions. As the inductance of L2 varies, the oscillator output (Q1C) varies around 3 MHz. This modulated frequency is applied to Q2, an emitter follower/buffer, and then sent out to the main unit.

The ferrite material is also affected by the magnetic field of the earth. Slight shifts in the magnetic field (i.e. orienting the probe in a different plane relative to the magnetic field of the earth) will cause a change in μ_o , which affects L1 and L2, moving the center frequency off 3 MHz. Circuitry on the RF/Demodulator Board (A2A1) detects this shift and varies the feedback voltage to CR2. This changes the capacitance of CR2 to bring the center frequency back to 3 MHz.

TABLE C.1
TABLE OF EQUIVALENT MAGNETIC UNITS FOR $\mu = \mu^0$

<p>1 tesla = 1 weber/m² 1 tesla = 104 gauss 1 tesla = 109 gammas 1 tesla = 7.96 x 10⁵ ampere/meter</p>
<p>1 nanotesla = 1 gamma 1 nanotesla = 796 μampere turns/meter 1 nanotesla = 10⁻⁵ gauss 1 nanotesla = 10³ picotesla</p>
<p>1 μampere turn/meter = 1.256 x 10⁻³ gammas 1 μampere turn/meter = 1.256 x 10⁻³ nanotesla 1 μampere turn/meter = 1.256 picotesla 1 μampere turn/meter = 1.256 x 10⁻⁸ gauss</p>
<p>1 picotesla = 0.796 μampere turn/meter 1 picotesla = 10⁻³ nanotesla 1 picotesla = 1 milligamma 1 picotesla = 1.256 x 10⁻⁸ gauss</p>
<p>1 gamma = 796 μampere turns/meter 1 gamma = 1 nanotesla 1 gamma = 10⁻⁵ gauss 1 gamma = 10³ picotesla</p>
<p>1 μampere turn/meter = +2 dB picotesla</p>

Figure C.4

Block Diagram EM-7530

Page C-13A

APPENDIX D EM-7530 APPLICATIONS

D-1.0 Introduction

This section describes some of the applications and uses for the EM-7530 Magnetic Field Strength Meter.

As a general rule, the maximum magnetic energy of a radiated electromagnetic field is equal to its maximum electric energy. When dealing with low frequency induction fields, however, the relationship between the magnetic and electric field energy compositions of the spectrum becomes more difficult to predict. But without adequate instrumentation (for experimentation and measurements), little can be accomplished concerning research into, design, or prediction of low frequency induction fields. The EM-7530 resolves this problem for researchers, designers, and for individuals whose primary interest is not the technology describing low frequency induction field phenomenon, but rather, the effects of existing or man-made fields upon their areas of expertise.

D-2.0 Environmental Measurements

One application for the EM-7530 is the measurement of the magnetic environment for under both laboratory and field conditions. Broadband environmental measurements can be made with the EM-7530 without ancillary equipment. Narrowband monitoring techniques can be used to obtain environmental level versus frequency data. The true component sensitivity of the EM-7530 also allows the vectorial relationship of the environment to be determined, the latter information being quite valuable when environmental sources are to be located and controlled.

Environmental measurements can be designed to provide a variety of information. The extensiveness of the measurements depends upon the exactness required in the description of a particular environment. The measurements could vary from a measurement of the broadband levels in a single location to narrowband measurements along the X, Y, and Z planes at points in a matrix designed to describe the space to be tested.

D-3.0 RFI/EMI Testing

Most military and federal specification measurements require the measurement sensor to be placed a designated distance from the equipment under test. The fields emanating from the equipment are then monitored. The specification limits depend upon a number of factors:

- a. The particular specification under which the equipment is being tested,
- b. The type of equipment or system being tested,
- c. The frequency at which the test is conducted.

One of the more important uses of the EM-7530 is for military specification compliance testing. The EM-7530 has two distinct advantages over other magnetic field sensing instruments in this application:

- 1) The EM-7530 response is constant from 20 Hz to 50kHz,
- 2) The EM-7530 can be directly calibrated.

Loop sensors have their greatest sensitivity at the higher frequencies, but suffer a significant loss of sensitivity at low frequencies. In addition, since loop sensors measure the rate of change of magnetic fields, their response to impulse or nonsinusoidal signals tends to be distorted. Hall-Effect and fluxgate type sensors generally find their applications in the measurement of static fields much greater than 0.01 nanoteslas. The variable- μ -ferrite sensor used in the EM-7530 characteristically has a linear amplitude response and high constant sensitivity across a wide bandwidth, thus making it exceptionally well-suited for RFI/EMI specification testing.

In addition, since the EM-7530 can be directly calibrated, the use of antenna and cable loss factors are not required to reduce the test data to limit compliance information.

Method RE01 of MIL-STD-462 is a typical application of the EM-7530 Magnetic Field Strength Meter.

D-4.0 Shielding Effectiveness Measurements

Measurements of shielding effectiveness of materials or enclosures is generally accomplished by generating a known field on one side of an enclosure or wall and measuring the field strength on the opposite side. The difference in the field strengths is the shielding effectiveness.

Lower frequency measurements have, in the past, been difficult because of instrument limitations. Loop sensors, used in measurements below 14 kHz, have inherent disadvantages, one of which is frequency dependent response. Another is poor low frequency sensitivity. Below 500 Hz, excessively high energy exciting fields are required before a usable signal is obtained from the loop.

The sensitivity of the EM-7530, however, allows relatively low level fields to be used for these tests. In addition, the sensor is small enough to permit use in confined quarters. If necessary, remote measurements can be made with large separation between sensor and electronics.

Figure D.1 shows the shielding effectiveness versus frequency characteristics of a typical nonpermeable conductive enclosure. For this experiment, a field was generated by an external coil and the resultant field measured by placing the EM-7530 sensor inside the enclosure.

Figures D.2 and D.3 show the narrowband measurements made with the technique shown in Figure D.4 on another enclosure. In this case, the higher frequency shielding effectiveness of the enclosure is readily apparent.

Figure D.1
Typical Shielded Enclosure Shielding Effectiveness

Figure D.2
Laboratory Magnetic Field Environment

Figure D.3
Magnetic Field Environment Within Enclosure

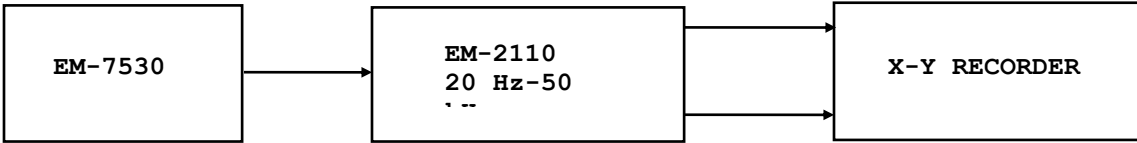

Figure D.4
Test Equipment Arrangement

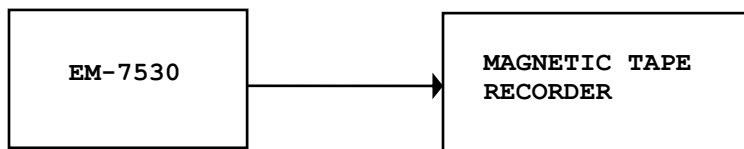

Figure D.5
Field Measurement Instrumentation Arrangement

D-5.0 Broadband And Narrowband Measurements

For some of the above applications, both broadband or narrowband measurements with the EM-7530 may be desirable.

The EM-7530 acts as a broadband magnetic transducer. The rms value of the analog voltage presentation corresponds to the total rms magnetic field intensity in the frequency spectrum of 20 Hz to 50 kHz.

For field or laboratory applications, it is occasionally desirable to make broadband recordings with the EM-7530 as shown in Figure D.5. The magnetic tape recording can later be analyzed in any manner desired. This technique is exceptionally convenient for field applications requiring narrowband measurement. The broadband data is preserved on magnetic tape and the narrowband analysis can be performed later at a more convenient location, thus making it unnecessary to transport the narrowband monitoring equipment to the field location. This magnetic tape method greatly increases the reliability of data taken in field locations.

A convenient automatic technique for obtaining narrowband data is shown in Figure D.4. In the arrangement shown, an automatically swept low frequency EMI meter, such as an Electro-Metrics Model EM-2110, and chart recorder are used to provide a permanent record of the mag-

netic field strength data versus frequency. The arrangement in Figure D.4 can also be automated using a computer controlling each instrument through their respective GPIB connector.

The same instrumentation technique could be used for narrowband analysis of data from the EM-7530 recorded on magnetic tape. If magnetic tape is to be analyzed as shown, a calibration signal should be recorded when the original data is recorded.

APPENDIX E EM-7530 SENSOR PROBE DATA

E-0.1 Introduction

The EM-7530 uses external sensor probes to detect and measure low-level magnetic fields. The EM-7536 Sensor Probe is supplied with each EM-7530 as a standard accessory. In addition, three optional Sensor Probes are also available--EM-7537, EM-7538, EM-7539.

E-2.0 Magnetic Field Sensor Probes

The EM-7536, EM-7537, EM-7538 B-Field sensor probes are available for use with the EM-7530 Magnetic Field Strength Meter. The EM-7536 Sensor Probe is shipped as a standard accessory with each EM-7530, while the two other sensor probes are offered as optional accessories.

a. EM-7536

Standard Sensor Probe, supplied with each EM-7530. 60-120 dB(pT) Broadband range. Used in performing tests in accordance with Method RE04 of MIL-STD-461B.

b. EM-7537

Optional High Level Sensor Probe. 100-160 dB(pT) Broadband range. Used in performing tests in accordance with Method RE01 of MIL-STD-461B.

c. EM-7538

Optional Uncalibrated Sniffer Probe. Similar to the EM-7536 Standard Sensor Probe, used for pinpointing localized magnetic sources.

Each Sensor Probe has an identical 8-pin connector at one end for connection to the Sensor Probe Cable. The other end of the Sensor Probe Cable is connected to the front panel Sensor Connector of the EM-7530.

With the EM-7530 turned-off, connect the Sensor Probe Cable to the front panel Sensor Connector. Connect the Sensor Probe selected to the other end of the Sensor Probe Cable.

The Sensor Probes are, electrically, magnetic dipoles and thus having a dipole pattern must be oriented for best sensitivity. Each probe is marked with an arrow indicating the direction of maximum sensitivity.

E- 3.0 E-Field Sensor Probe

In addition to the magnetic field sensor probes, the EM-7539 E-Field Sensor Probe is also available for use with the EM-7530 Magnetic Field Strength Meter.

a. EM-7539

Calibrated E-Field Sensor Probe This accessory allows the EM-7530 to measure electric field variations from 20 Hz to 50 kHz. When used, an antenna factor of 40 dB is added to the EM-7530 meter reading in dB(pT) to obtain the E-Field level in dB(μ V/m). Sensitivity is 2.6 mV/m [68 dB(μ V/m) or a EM-7530 meter indication of 28 dB(pT)].

The E-Field Sensor Probe has an 8-pin connector at one end for connection to the Sensor Probe Cable. The other end of the Sensor Probe Cable is connected to the front panel Sensor Connector of the EM-7530.